

REVISIONS		
LTR	DESCRIPTION	DATE

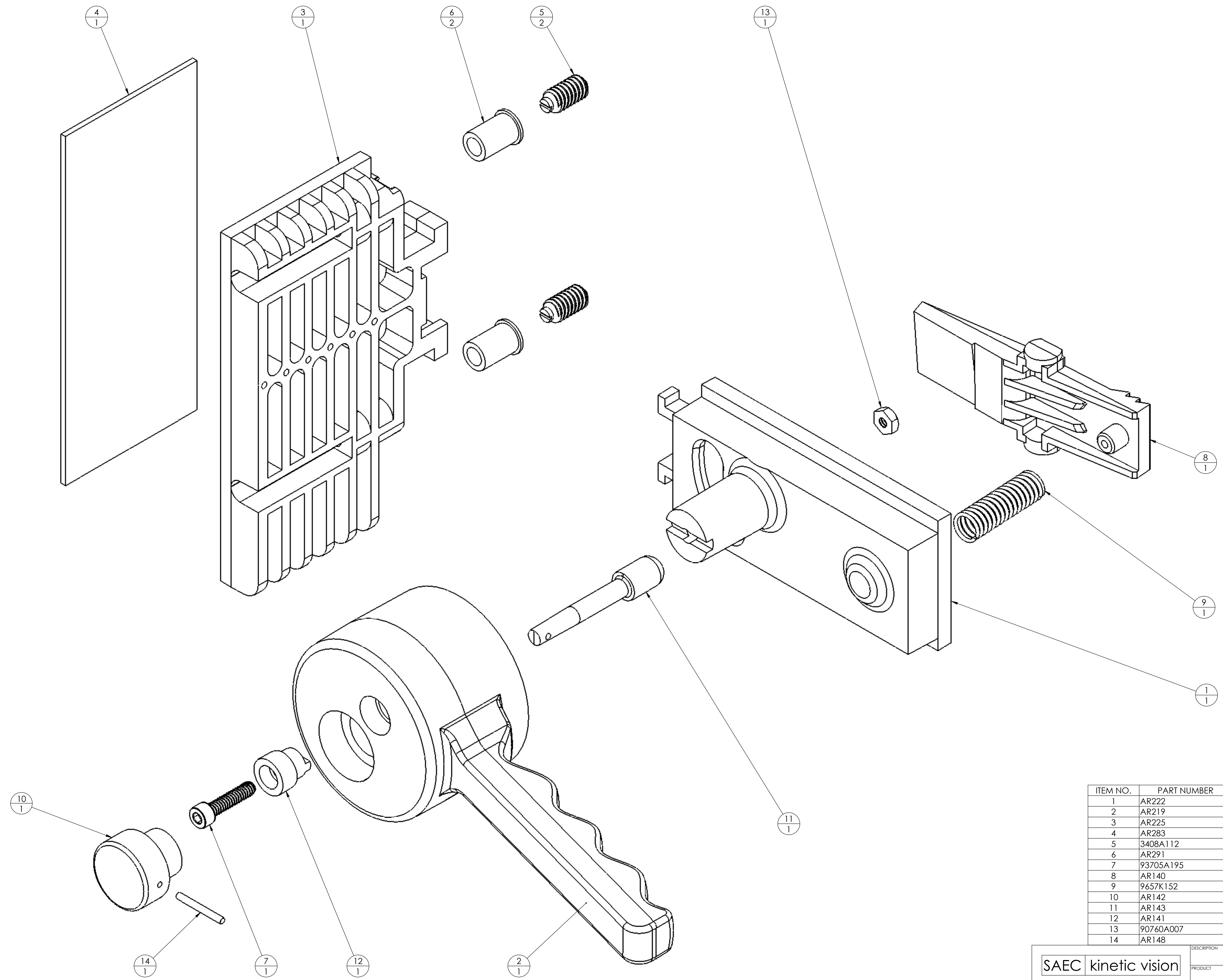

ITEM NO.	PART NUMBER	DESCRIPTION	QTY.
1	AR222	CAM CLAMP BASE	1
2	AR219	CAM CLAMP HANDLE	1
3	AR225	CAM CLAMP FENCE	1
4	AR283	RUBBER SURFACE - FENCE	1
5	3408A112	McMASTER #3408A112	2
6	AR291	McMASTER #94615A116	2
7	93705A195	McMASTER #93705A195	1
8	AR140	CAM CLAMP PAWL	1
9	9657K152	McMASTER #9657K152	1
10	AR142	CAM CLAMP BUTTON	1
11	AR143	CAM CLAMP ACTUATOR	1
12	AR141	CAM CLAMP HANDLE CAP	1
13	90760A007	McMaster #90760A007	1
14	AR148	McMASTER #90145A318	1

SAEC kinetic vision		CAM CLAMP ASSEMBLY	
PRODUCT	ROUTER BOSS	MATERIAL	SEE BOM
DESCRIPTION	AR_SUB_007		
DRAWN BY	CAG	SCALE	1:1
DATE	4/3/2008	UNITS	IN
TOLERANCES UNLESS OTHERWISE SPECIFIED: X.XX = ± .01 X.XXX = ± .005 ANGULAR = ± 1/2°		APPROVAL FROM SAEC/kinetic vision	
SHEET 1 OF 1		CAD	